

Soilmec R-210

Several jobsites require equipment suitable to have short rig up time and easy to operate in narrow locations. SOILMEC meets these requirements marketing the new R-210, a solid machine completely self-erecting with high performances and minimum operating costs.

Its outstanding features are:

- Higher torque on rotary table: 96 kNm.
- Higher drilling speed: 43 rpm.
- Touch screen monitor handling rig performances.
- Self-erecting rig; Kelly bar does not need to be removed.
- No special road permits required.



Technical Data

Max pile diameter	750mm
Max pile depth	18m
Max nominal extraction force	280 kN
Transport weight	26 tons

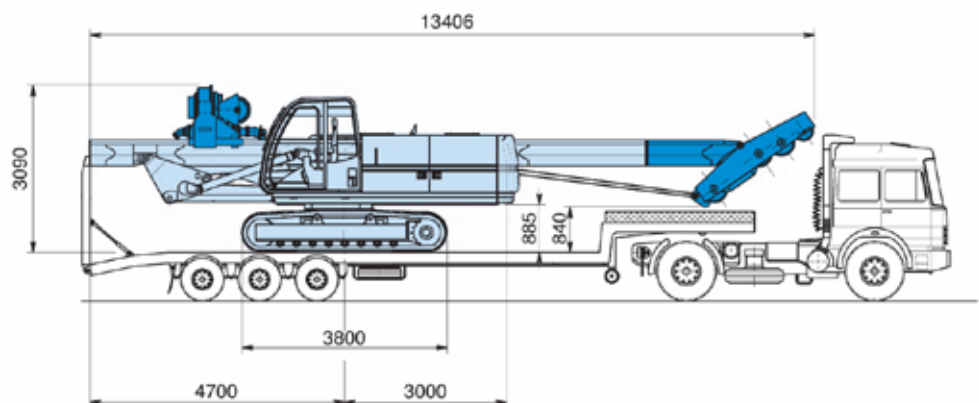



Your building
on firm foundations

 **neil**
FOUNDATIONS SYSTEMS

Neil Foundations Systems Ltd

Stake Works Invincible Road Farnborough

Hampshire GU14 7QT

Tel: 01252 550222 Fax: 01252 550223

piling@neilfoundations.co.uk www.neilfoundations.co.uk



INVESTOR IN PEOPLE

